

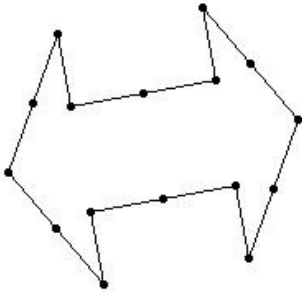

1. If the length between any two consecutive points is 4.5 cm, find the perimeter of the given figure



- (i) 71.00 cm (ii) 70.00 cm (iii) 74.00 cm (iv) 73.00 cm (v) 72.00 cm

2. If the length between any two consecutive points is 5.6 cm, find the perimeter of the given figure

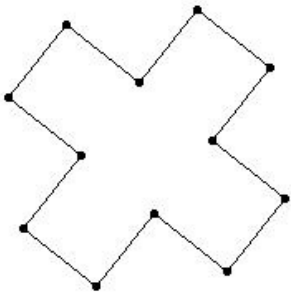

- (i) 67.20 cm (ii) 65.20 cm (iii) 69.20 cm (iv) 68.20 cm (v) 66.20 cm

3. If the length between any two consecutive points is 4.8 cm, find the perimeter of the following figure

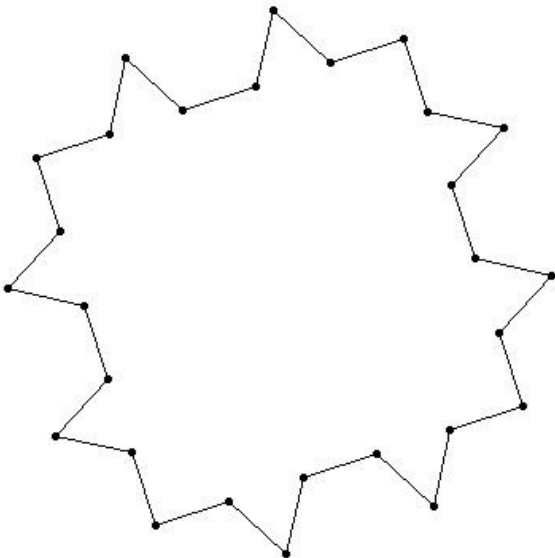

- (i) 132.40 cm (ii) 135.40 cm (iii) 136.40 cm (iv) 133.40 cm (v) 134.40 cm

4. If the length between any two consecutive points is 5.4 cm, find the perimeter of the given figure

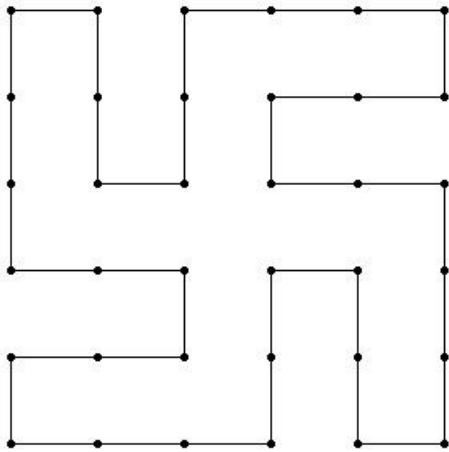

- (i) 196.40 cm (ii) 194.40 cm (iii) 193.40 cm (iv) 192.40 cm (v) 195.40 cm

5. If the length between any two consecutive points is 7.5 cm, find the perimeter of the given figure

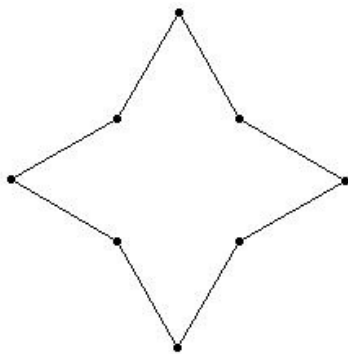

- (i) 60.00 cm (ii) 61.00 cm (iii) 59.00 cm (iv) 58.00 cm (v) 62.00 cm

6. If the length between any two consecutive points is 5.6 cm, find the perimeter of the given figure

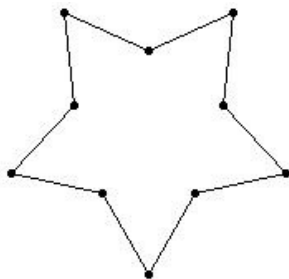

- (i) 55.00 cm (ii) 54.00 cm (iii) 58.00 cm (iv) 57.00 cm (v) 56.00 cm

7. If the length between any two consecutive points is 5.1 cm, find the perimeter of the given figure

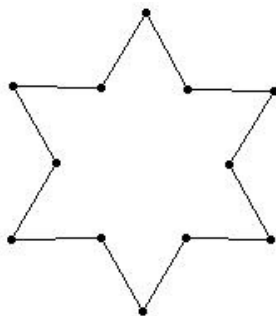

- (i) 62.20 cm (ii) 60.20 cm (iii) 61.20 cm (iv) 59.20 cm (v) 63.20 cm

8. If the length between any two consecutive points is 5.9 cm, find the perimeter of the given figure

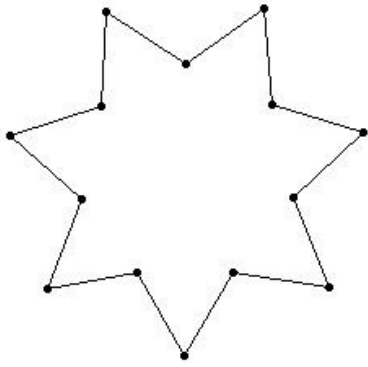

- (i) 80.60 cm (ii) 84.60 cm (iii) 81.60 cm (iv) 82.60 cm (v) 83.60 cm

9. If the length between any two consecutive points is 6.7 cm, find the perimeter of the given figure

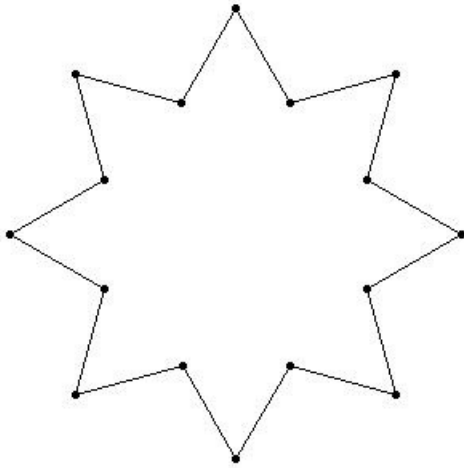

- (i) 106.20 cm (ii) 105.20 cm (iii) 108.20 cm (iv) 107.20 cm (v) 109.20 cm

10. If the length between any two consecutive points is 8.3 cm, find the perimeter of the given figure

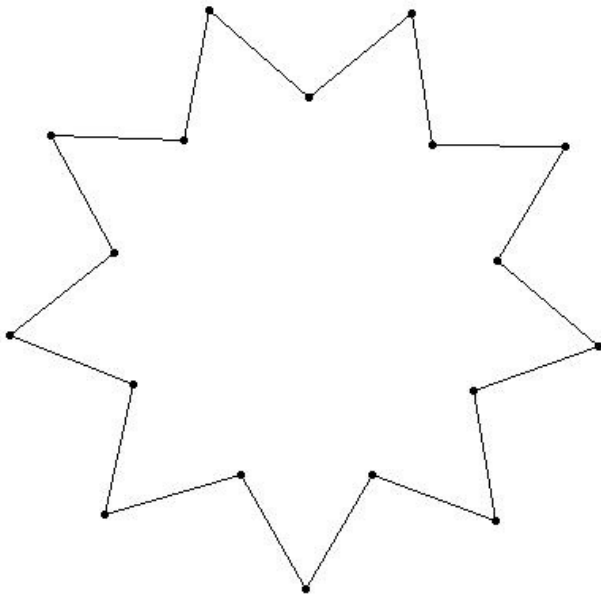

- (i) 150.40 cm (ii) 151.40 cm (iii) 149.40 cm (iv) 147.40 cm (v) 148.40 cm

11. If the length between any two consecutive points is 4.8 cm, find the perimeter of the given figure

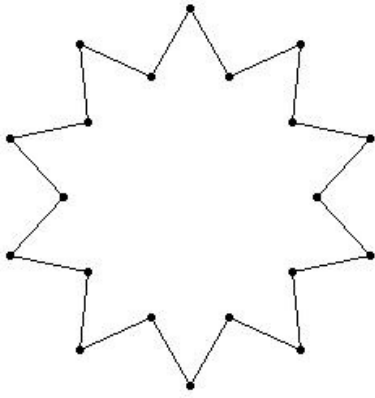

- (i) 95.00 cm (ii) 97.00 cm (iii) 96.00 cm (iv) 98.00 cm (v) 94.00 cm

12. If the length between any two consecutive points is 6.0 cm, find the perimeter of the following figure

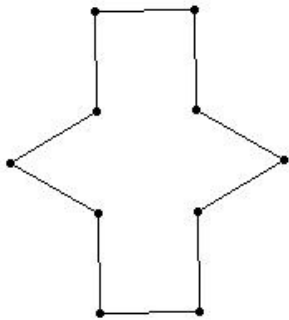

- (i) 61.00 cm (ii) 60.00 cm (iii) 58.00 cm (iv) 62.00 cm (v) 59.00 cm

13. Find the perimeter of the shaded region given below

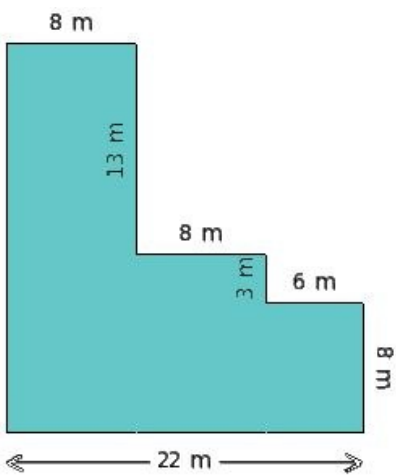

- (i) 87.00 m (ii) 92.00 m (iii) 95.00 m (iv) 97.00 m (v) 89.00 m

14. Find the perimeter of the shaded region given below

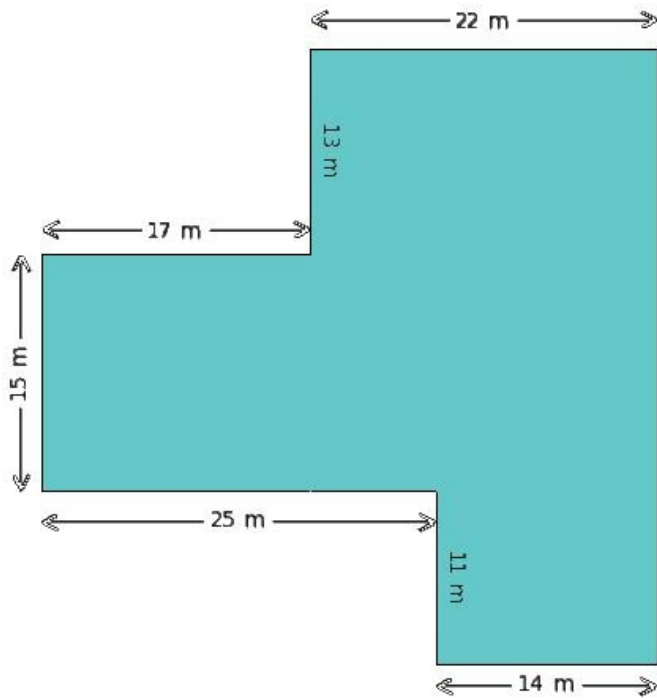

- (i) 164.00 m (ii) 144.00 m (iii) 172.00 m (iv) 152.00 m (v) 156.00 m

15. Find the perimeter of the shaded region given below

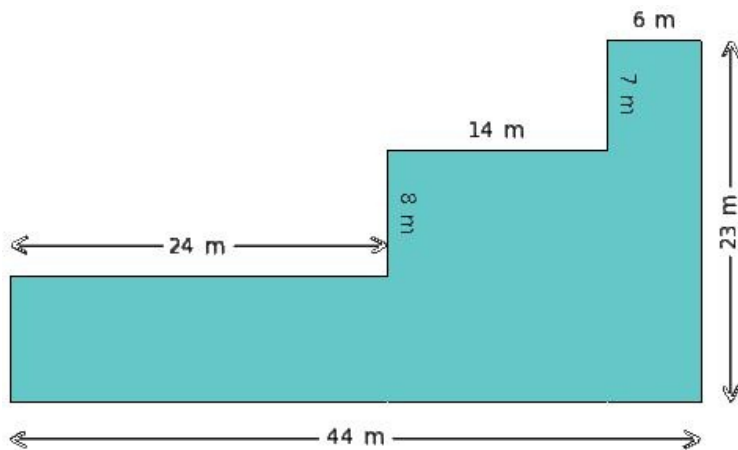

- (i) 151.00 m (ii) 111.00 m (iii) 159.00 m (iv) 134.00 m (v) 120.00 m

16. Find the perimeter of the shaded region given below

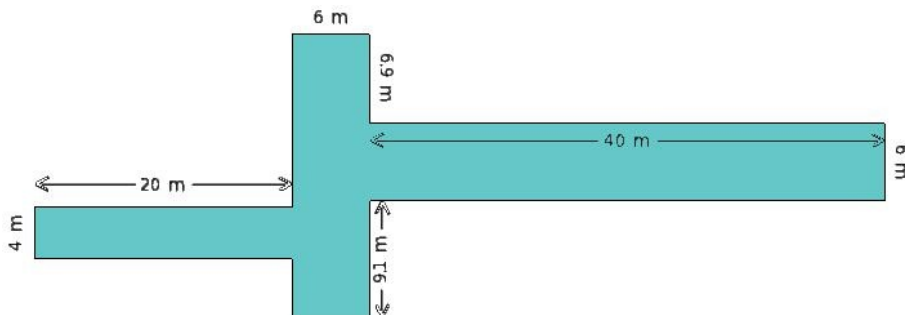

- (i) 176.00 m (ii) 199.00 m (iii) 170.00 m (iv) 178.00 m (v) 158.00 m

17. Find the perimeter of the shaded region given below

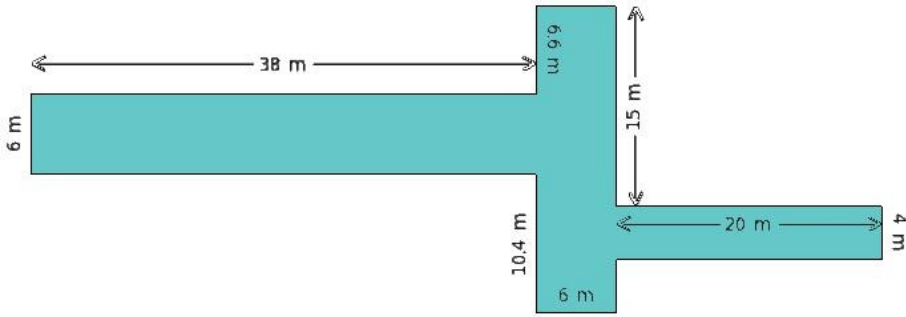

- (i) 179.00 m (ii) 150.00 m (iii) 158.00 m (iv) 174.00 m (v) 192.00 m

18. Find the perimeter of the shaded region given below

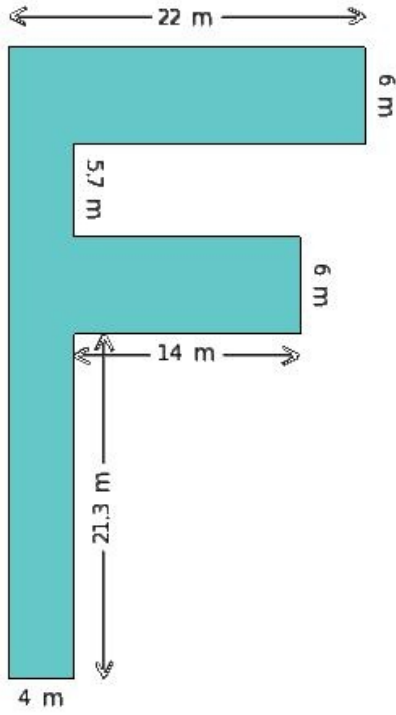

- (i) 165.00 m (ii) 147.00 m (iii) 122.00 m (iv) 157.00 m (v) 150.00 m

19. Find the perimeter of the shaded region given below

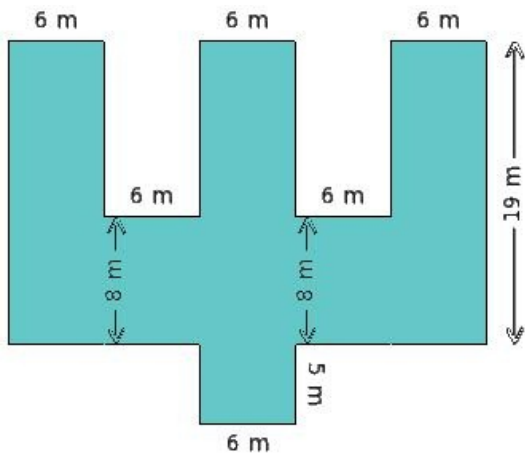

- (i) 152.00 m (ii) 127.00 m (iii) 168.00 m (iv) 140.00 m

20. Find the perimeter of the shaded region given below

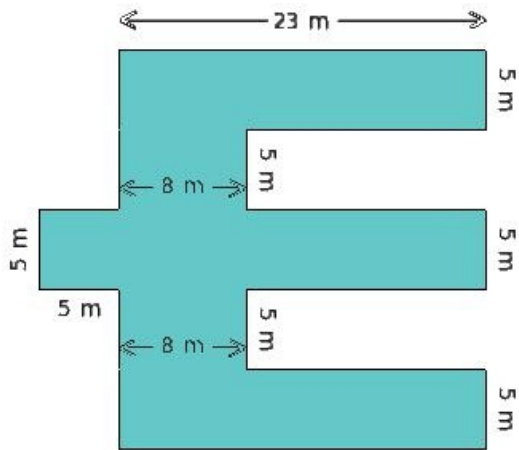

- (i) 152.00 m (ii) 183.00 m (iii) 148.00 m (iv) 192.00 m (v) 166.00 m

21. Find the perimeter of the shaded region given below

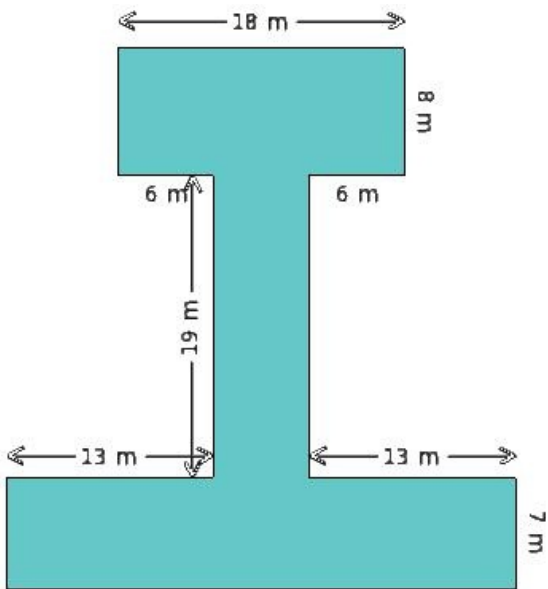

- (i) 168.00 m (ii) 141.00 m (iii) 152.00 m (iv) 170.00 m (v) 156.00 m

## Assignment Key

1) (v)	2) (i)	3) (v)	4) (ii)	5) (i)	6) (v)
7) (iii)	8) (iv)	9) (iv)	10) (iii)	11) (iii)	12) (ii)
13) (ii)	14) (v)	15) (iv)	16) (i)	17) (iv)	18) (v)
19) (i)	20) (v)	21) (v)			